

SPÉCIFICATIONS POUR CADRES

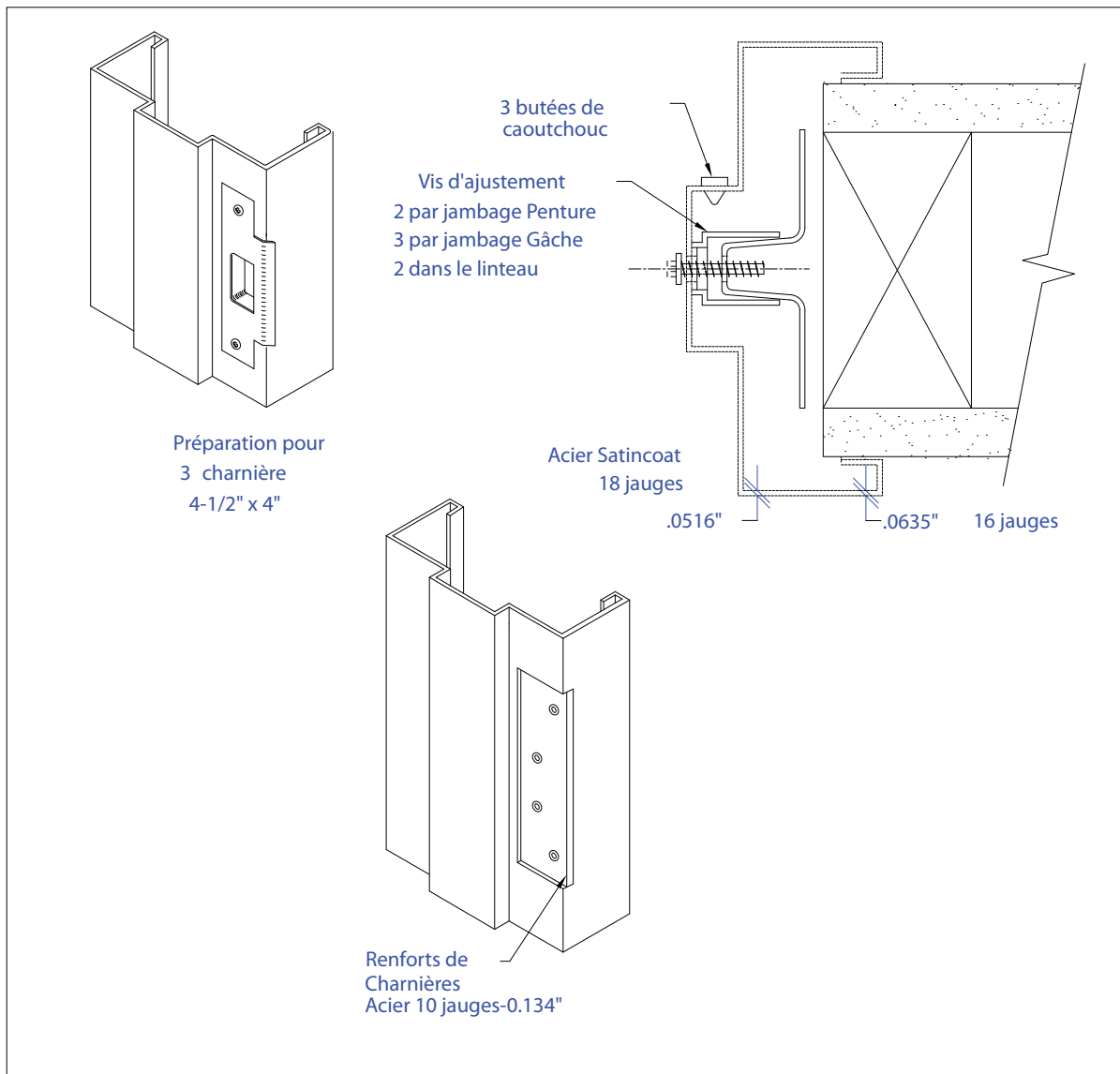

CADRE MÉCANIQUE SPÉCIFICATIONS

CM-22DR, CM-20DR

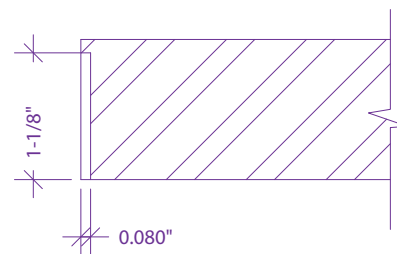
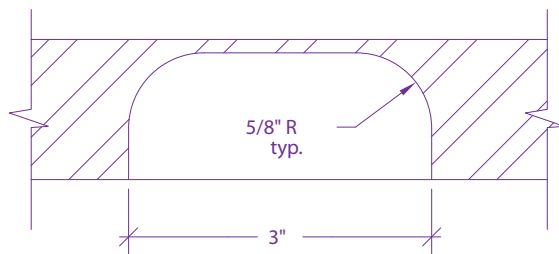
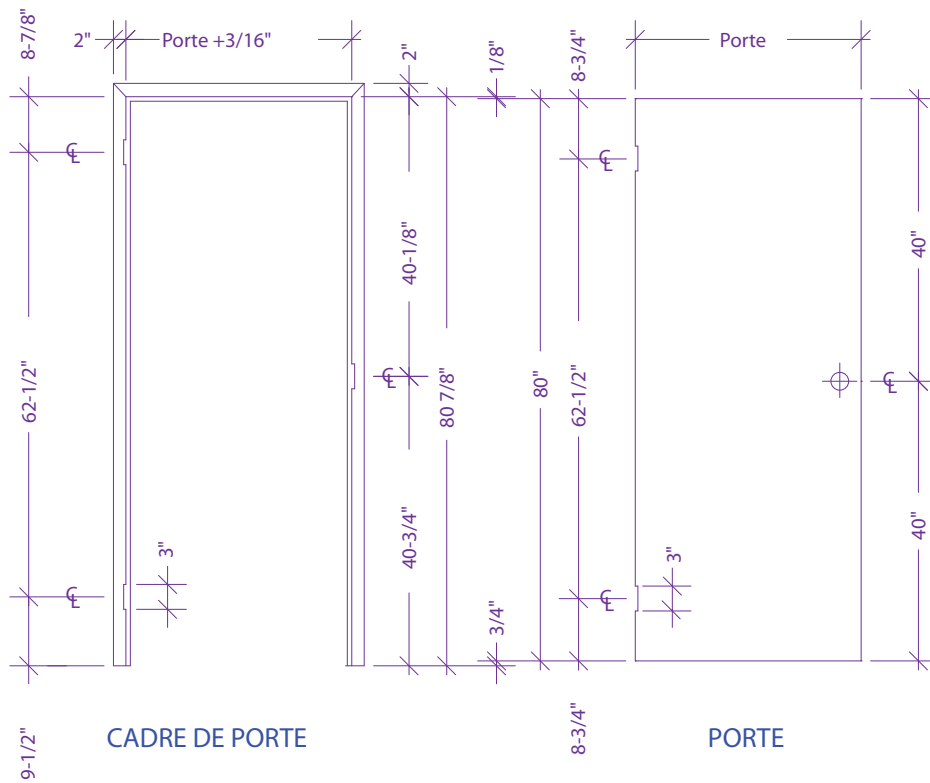

PRÉPARATION DE CHARNIÈRES POUR PORTES DE BOIS

CADRE MÉCANIQUE SPÉCIFICATIONS

CM-22DR, CM-20DR

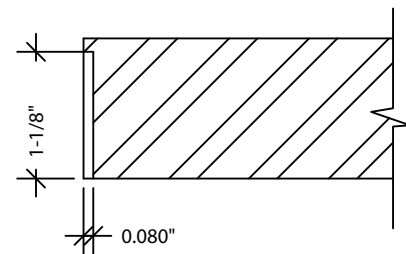
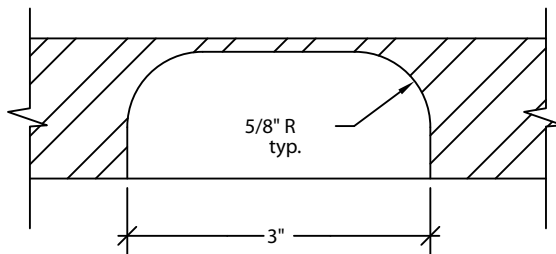
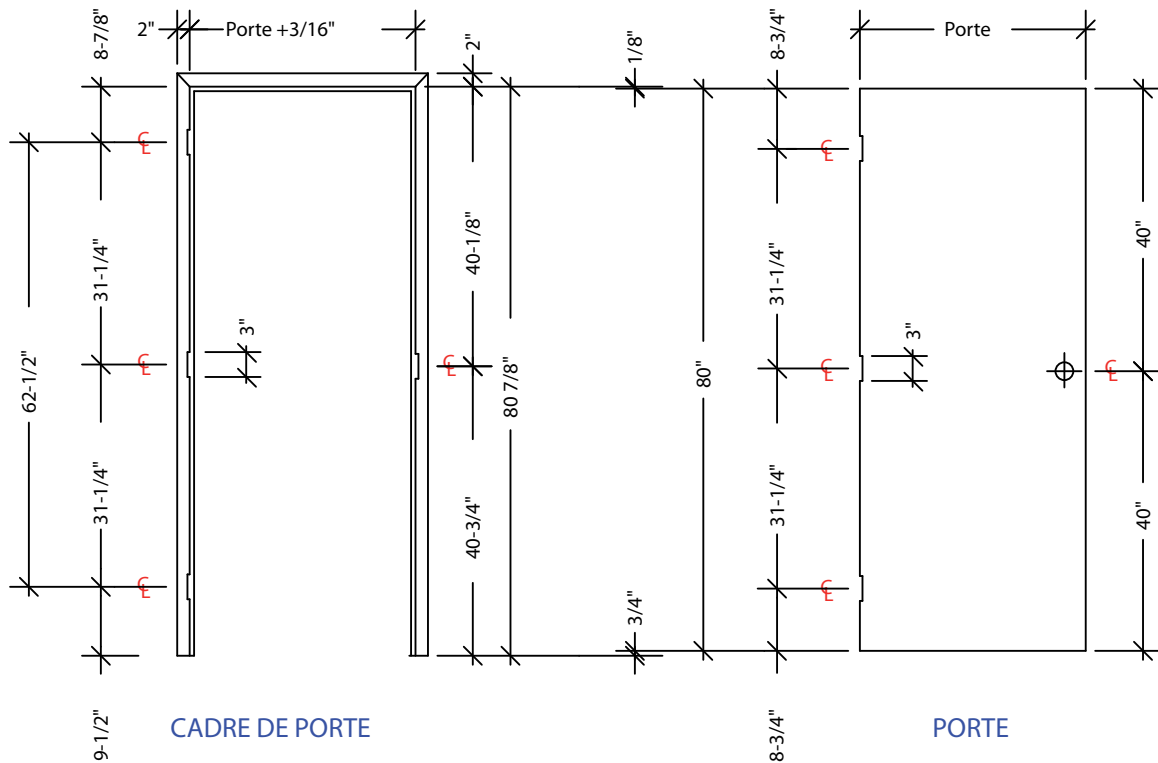

PRÉPARATION DE CHARNIÈRES POUR PORTES DE BOIS.

CADRE MÉCANIQUE SPÉCIFICATIONS

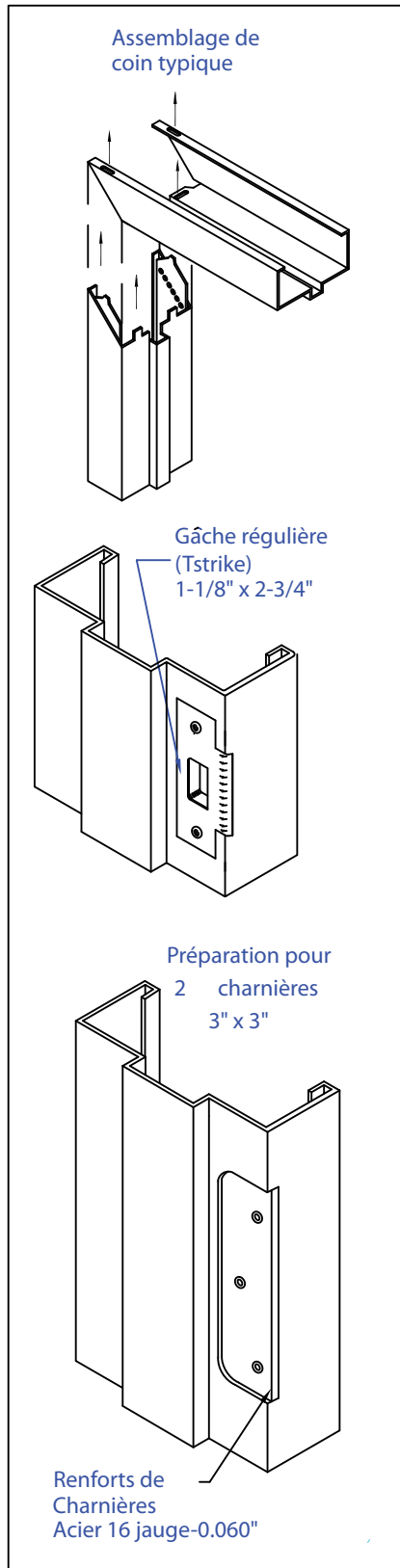

CM-22DR, CM-20DR

COUPE "A"

2 butées de caoutchouc

Vis d'ajustement 2 par jambage et 2 dans le linteau

Acier Satincoat 22 jauge (0.0336) ou 20 jauge (0.0396)

COUPE "B"

renfort de charnière

1/2"

1-1/2"

1/2"

4" @ 5-5/8"

1" @ 2-5/8"

3-5/8" @ 4-5/8"

1-1/2"

5/8"

2"

1/2"

NOTE:

Ouverture de mur	
Largeur	Cadre + 2"
Hauteur	Cadre + 1"

CADRES À ONGLET SOUDÉS OU MÉCANIQUE SPÉCIFICATIONS

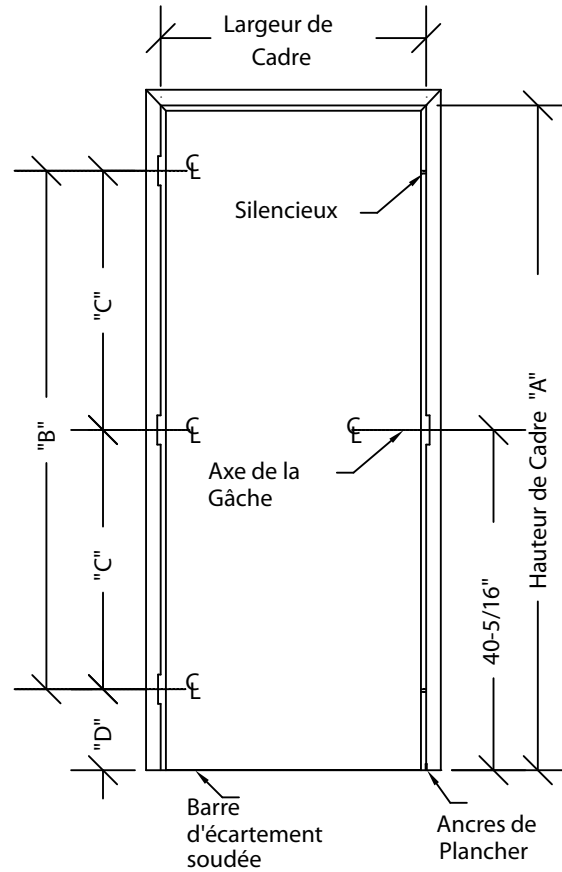
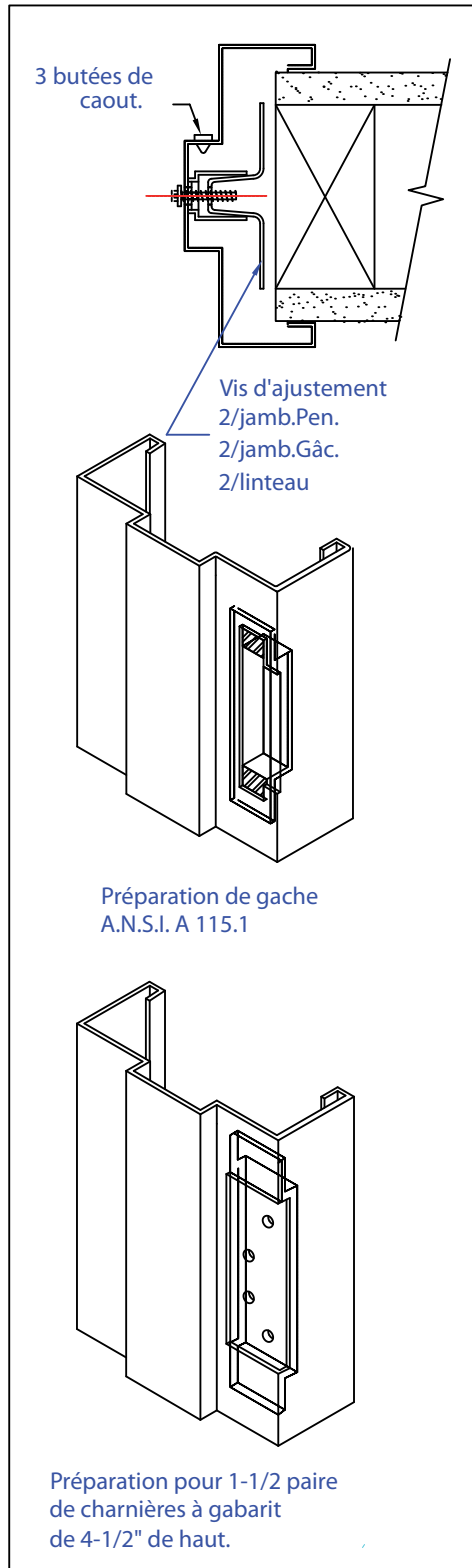

ÉLÉVATION

HAUTEUR	6'-8"	6'-10"	7'-0"
DIMENSION "A"	80"	82"	84"
DIMENSION "B"	59-7/8"	61-7/8"	63-7/8"
DIMENSION "C"	29-15/16"	30-15/16"	31-15/16"
DIMENSION "D"	10-3/8"	10-3/8"	10-3/8"

CADRES À ONGLET SOUDÉS ou MÉCANIQUE SPÉCIFICATIONS

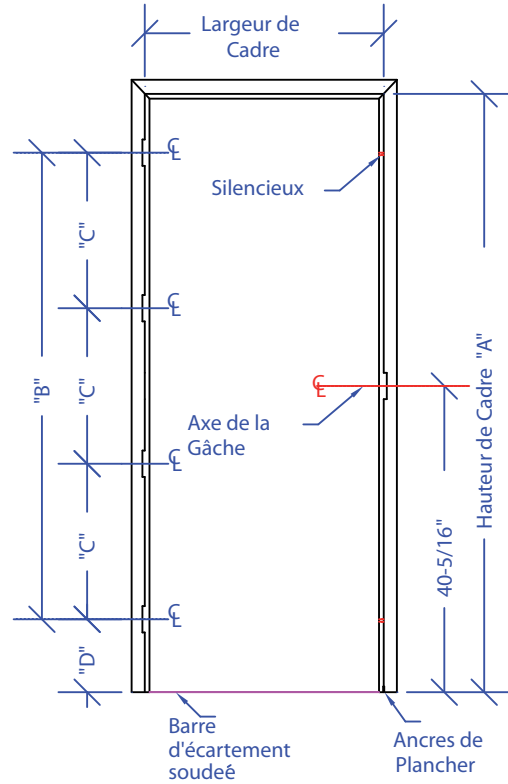
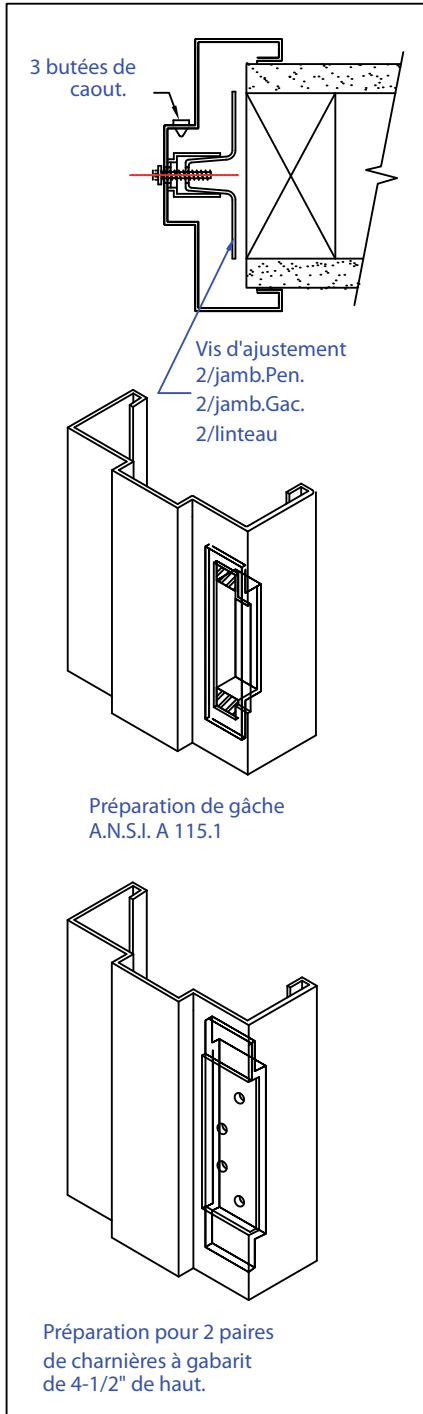

ÉLÉVATION

HAUTEUR	6'-8"	6'-10"	7'-0"
DIMENSION "A"	80"	82"	84"
DIMENSION "B"	60"	61-7/8"	63-3/4"
DIMENSION "C"	20"	20-5/8"	21-1/4"
DIMENSION "D"	10-1/4"	10-3/8"	10-1/2"

CADRES À ONGLET SOUDÉS ou MÉCANIQUE

SPÉCIFICATIONS

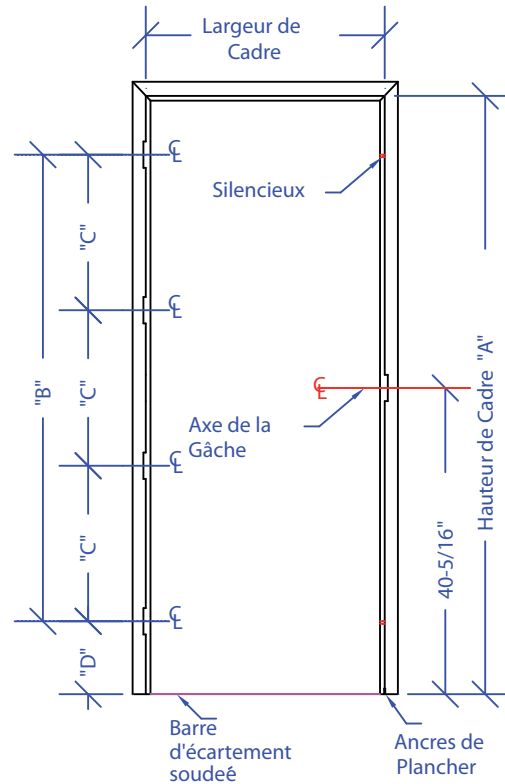
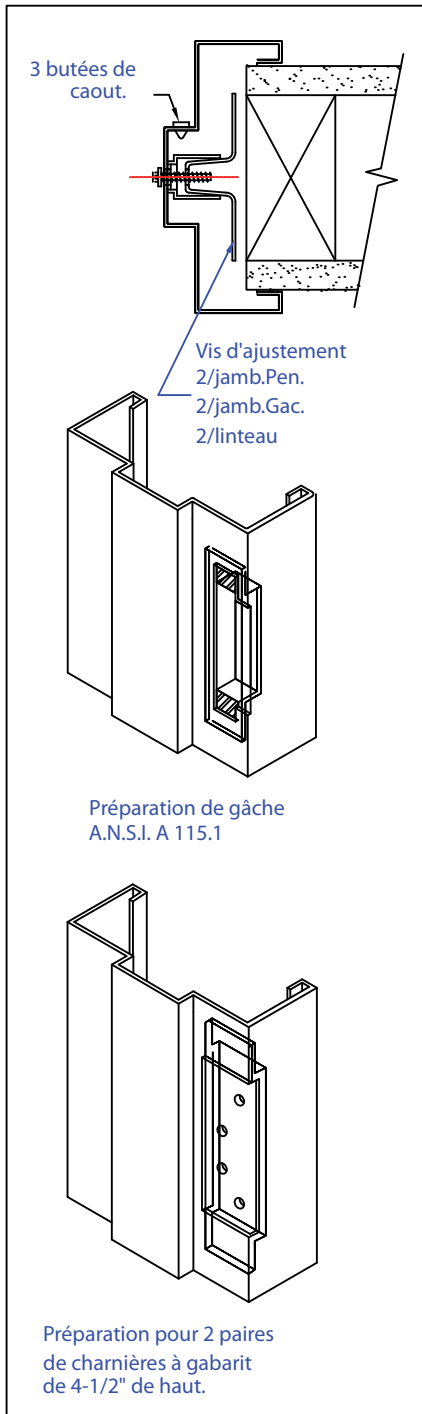

ÉLÉVATION

HAUTEUR	6'-8"	6'-10"	7'-0"
DIMENSION "A"	80"	82"	84"
DIMENSION "B"	60"	61-7/8"	63-3/4"
DIMENSION "C"	20"	20-5/8"	21-1/4"
DIMENSION "D"	10-1/4"	10-3/8"	10-1/2"

CADRES À ONGLET SPÉCIFICATIONS

CADRE DE PORTE HOLLANDAISE

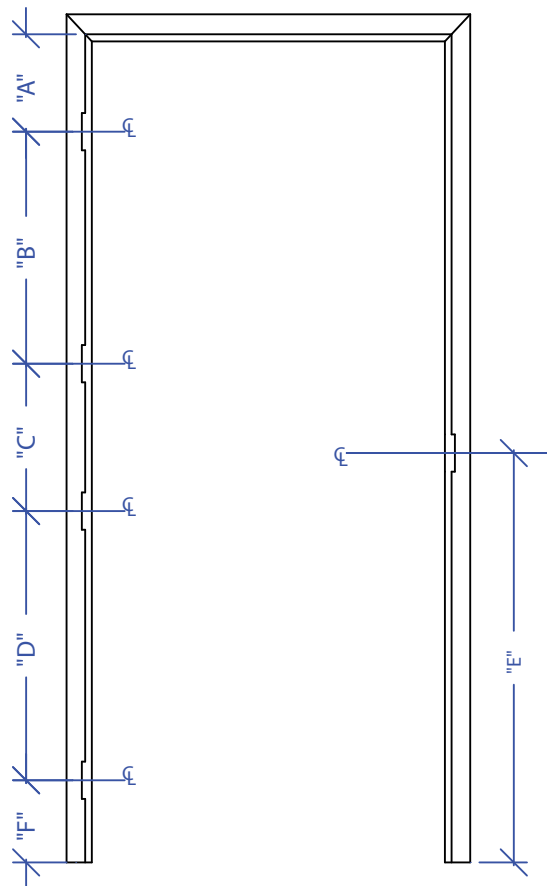

DIMENSIONS CADRE	"A"	"B"	"C"	"D"	"E"	"F"
7'-0"	9-3/4"	22-1/2"	19-1/2"	21-7/8"	37"	10-3/8"
6'-10"	9-3/4"	20-1/2"	19-1/2"	21-7/8"	37"	10-3/8"
6'-8"	9-3/4"	18-1/2"	19-1/2"	21-7/8"	37"	10-3/8"