

# THERMAL BREAK FRAMES

Métalec manufactures steel frames designed specifically for the exterior openings, adapting perfectly to the climatic fluctuations.

The thermally broken frames are manufactured in two parts separated by a low thermal conductive PVC flashing which eliminates thermal bridge. The two parts are retained together by a Z-shaped steel reinforcement eliminating thermal bond between the exterior and interior door frame faces.

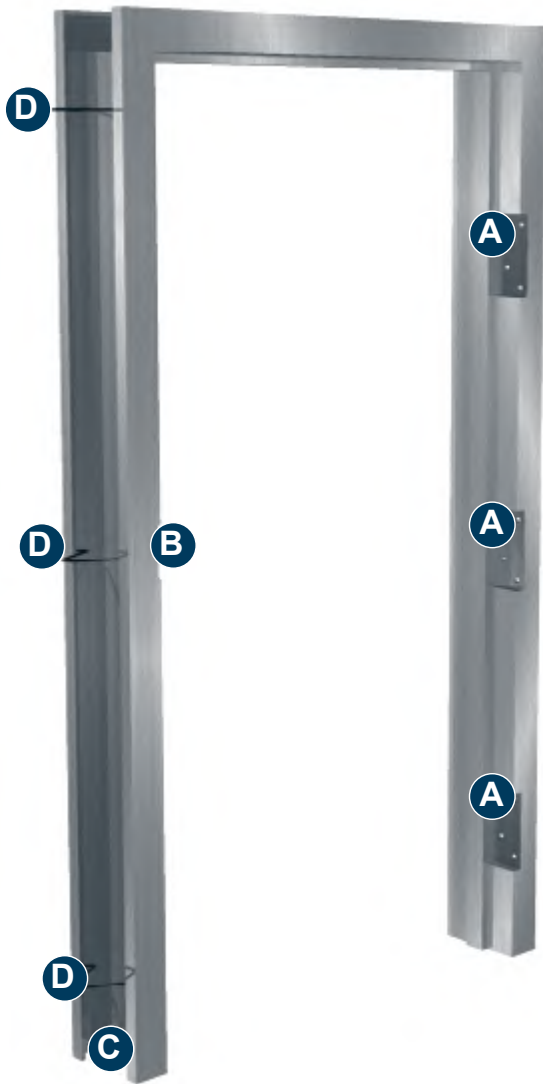
## Technical details

- The steel frames are manufactured using 16 or 14 gauge galvanized steel;
- The frames are supplied knockdown or welded;
- The frame anchors are determined according to the type of installation and wall composition;
- The frames are prepared to receive the specified hardware;
- The single openings have three rubber bumpers per strike jamb and the double openings have two rubber bumpers on the head.

## Recommendations

To optimize a low conductivity in your steel frame, we recommend the use of a polyisocyanurate insulated door, as manufactured by Métalec

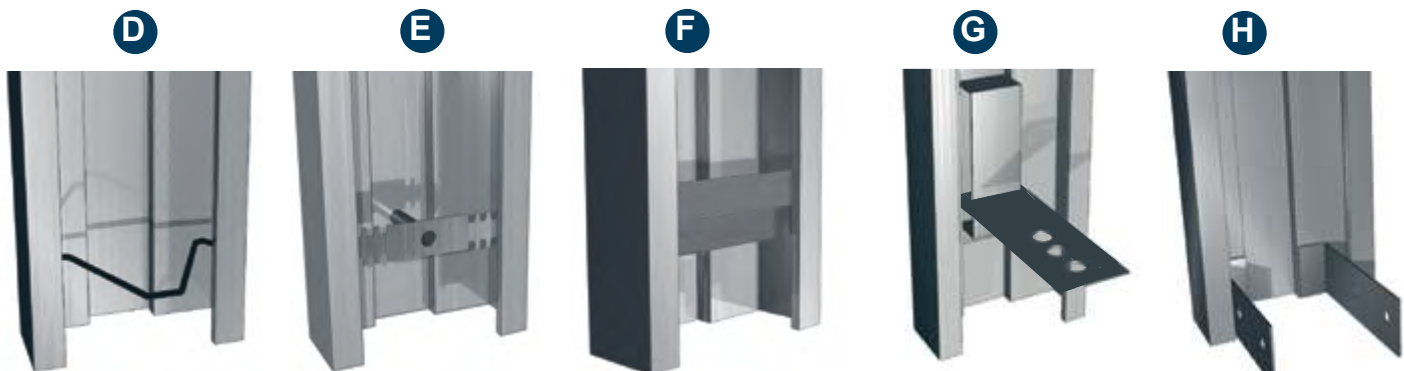




**ILLUSTRATION:**

- A- 10 gauge angular hinge reinforcement
- B- ANSI A115.1 strike preparation (ASA)
- C- Floor anchor (ATT #3)
- D- Masonry wall anchor (ATT #5)
- E- Existing wall anchor (ATT #6)
- F- Steel stud anchor (ATT #8)
- G- Masonry wall anchor (ATT #4)
- H- Wood stud anchor (ATT #7)

**SEVERAL TYPES OF ANCHOR:**



N.B.: Other hardware preparations are also available upon request.